

Reneo D 181 S14

Heat and energy recovery air handling units

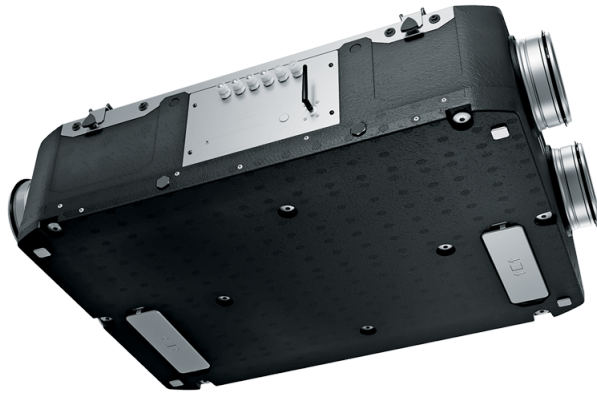

- Maximum airflow: 181
- Sound pressure level LpA at 3 m: 29
- Heat exchanger type: Counter flow
- Extract filter: Coarse > 60 %
- Supply filter: Coarse > 60 % (G4) (option: ePM1 60 % (F7))
- Sound insulation
- Motor type: EC
- Bypass: Manual
- Control: Wired control panel
- Casing material: EPP
- Humidity sensor: Optional
- CO2 sensor: Optional

| | Unit of measurement | Reneo D 181 S14 |
|-----------------------------------|---------------------|---|
| Connected air duct size | mm | 160 |
| Speed | - | 0 |
| Phases | - | 1 |
| Minimum supply voltage | V | 230 |
| Maximum supply voltage | V | 230 |
| Power supply frequency | Hz | 50/60 |
| Rated power | W | 53 |
| Unit current | A | 0.49 |
| Maximum airflow | m ³ /h | 181 |
| Sound pressure level LpA at 3 m | dB(A) | 29 |
| Heat recovery efficiency, max | % | 91 |
| Heat exchanger type | - | Counter flow |
| Heat exchanger material | - | Polystyrene |
| Weight | kg | 12 |
| Extract filter | - | Coarse > 60 % |
| Supply filter | - | Coarse > 60 % (G4) (option: ePM1 60 % (F7)) |
| Transported air temperature (max) | °C | 45 |
| Ambient air temperature min | °C | 1 |
| Ambient air temperature max | °C | 40 |
| Ambient air humidity max | % | 60 |
| Ingress protection rating | - | IP22 |

| | | |
|--|---|------|
| Ingress protection rating of the drive | - | IP44 |
|--|---|------|

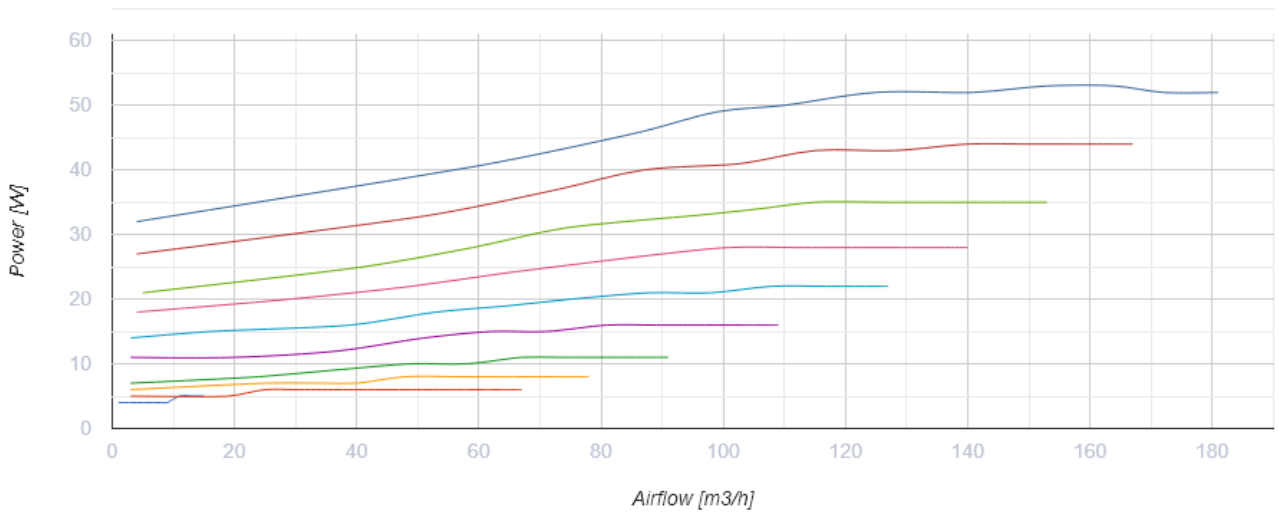
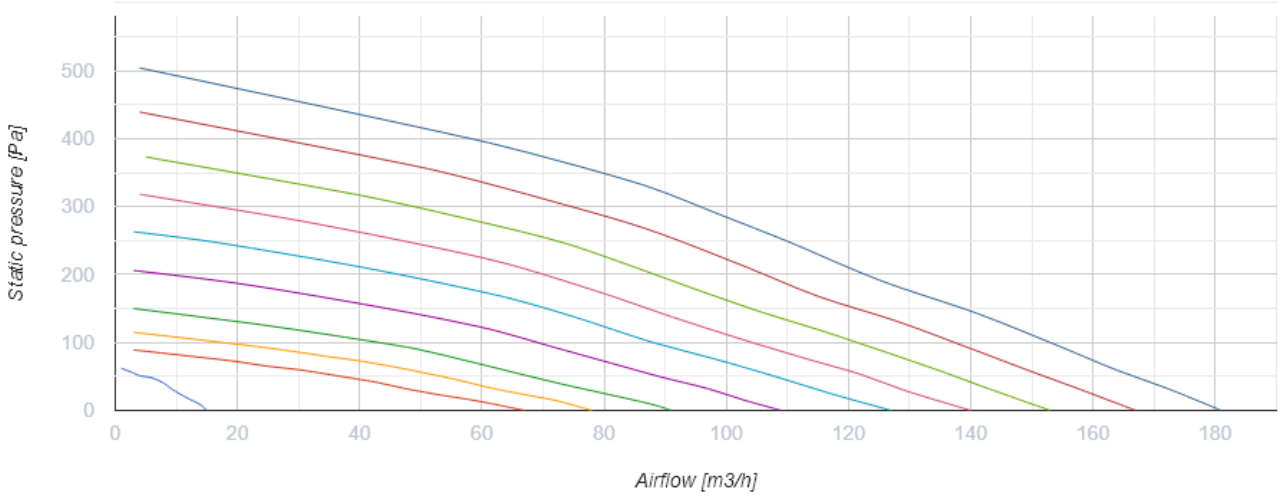

Dimensions

| Ø D | H | L | L1 | W / B | W1 / B1 |
|-----|-----|-----|-----|-------|---------|
| 160 | 272 | 930 | 627 | 640 | 300 |

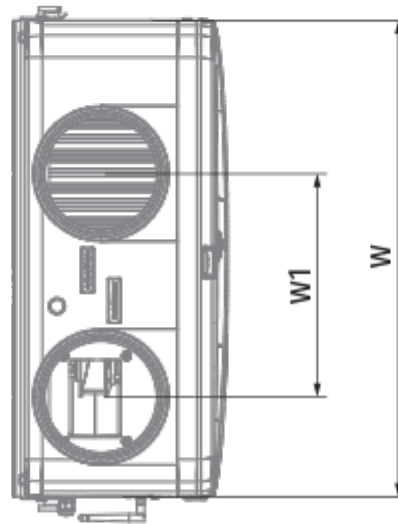
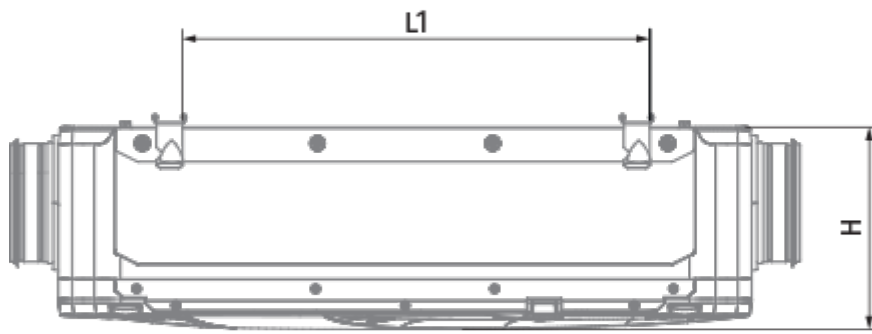
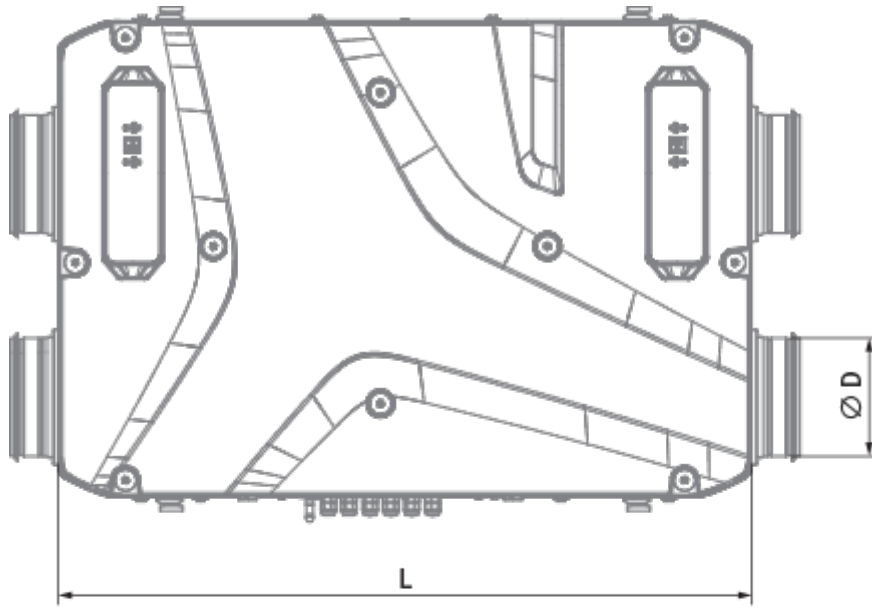

Ecodesign

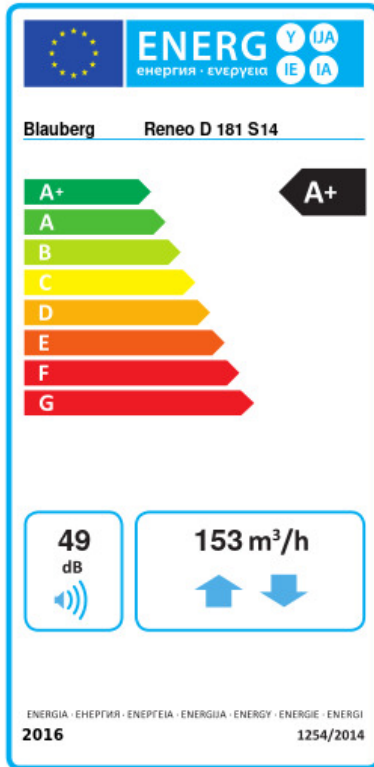

| | | | | | | |
|---|----------------------|---------|------|------|------|---|
| Trademark | Blauberg | | | | | |
| Model | Reneo D 181 S14 | | | | | |
| Specific energy consumption (SEC) (kWh/(m ² /a)) | Cold | Average | | Warm | | |
| | 82.1 | A+ | 43.2 | A+ | 18.2 | E |
| Type of ventilation unit | Bidirectional | | | | | |
| Type of drive installed | Variable speed | | | | | |
| Type of heat recovery system | Recuperative | | | | | |
| Thermal efficiency of heat recovery (%) | 87 | | | | | |
| Maximum flow rate (m ³ /h) | 153 | | | | | |
| Electric power input (W) | 53 | | | | | |
| Reference flow rate (m ³ /s) | 0.03 | | | | | |
| Reference pressure difference (Pa) | 50 | | | | | |
| Specific power input (SPI) (W/(m ³ /h)) | 0.204 | | | | | |
| Control typology | Local demand control | | | | | |
| Maximum internal leakage rates (%) | 2.7 | | | | | |
| Maximum external leakage rates (%) | 2.7 | | | | | |
| Sound power level (dB(A)) | 49 | | | | | |
| Declared typology | RVU BVU | | | | | |
| The annual electricity consumption (AEC) (kWh/a) | Cold | Average | | Warm | | |
| | 690 | 153 | | 108 | | |
| The annual heating saved (AHS) (kWh/a) | Cold | Average | | Warm | | |
| | 9060 | 4631 | | 2094 | | |