



KOMFORT EC SB 350-E S14

Heat and humidity recovery air handling units

- Maximum airflow: 450
- Sound pressure level LpA at 3 m: 28
- Heat exchanger type: Counter flow
- Extract filter: G4
- Supply filter: F7 (option: G4)
- Sound insulation
- Motor type: EC
- Enthalpy heat exchanger
- Bypass: Manual
- Control: Wired control panel
- Casing material: Coated steel
- Humidity sensor: Optional
- CO2 sensor: Optional

	Unit of measurement	KOMFORT EC SB 350-E S14
Connected air duct size	mm	160
Speed	-	1
Phases	-	1
Minimum supply voltage	V	230
Maximum supply voltage	V	230
Power supply frequency	Hz	50/60
Rated power	W	178
Unit current	A	1.4
Maximum airflow	m ³ /h	450
Sound pressure level LpA at 3 m	dB(A)	28
Heat recovery efficiency, max	%	91
Heat exchanger type	-	Counter flow
Heat exchanger material	-	Enthalpy
Weight	kg	64
Extract filter	-	G4
Supply filter	-	F7 (option: G4)
Transported air temperature (max)	°C	40
Transported air temperature (min)	°C	-25
Ambient air temperature min	°C	1
Ambient air temperature max	°C	40
Ambient air humidity max	%	60

Ingress protection rating	-	IP20
Ingress protection rating of the drive	-	IP44

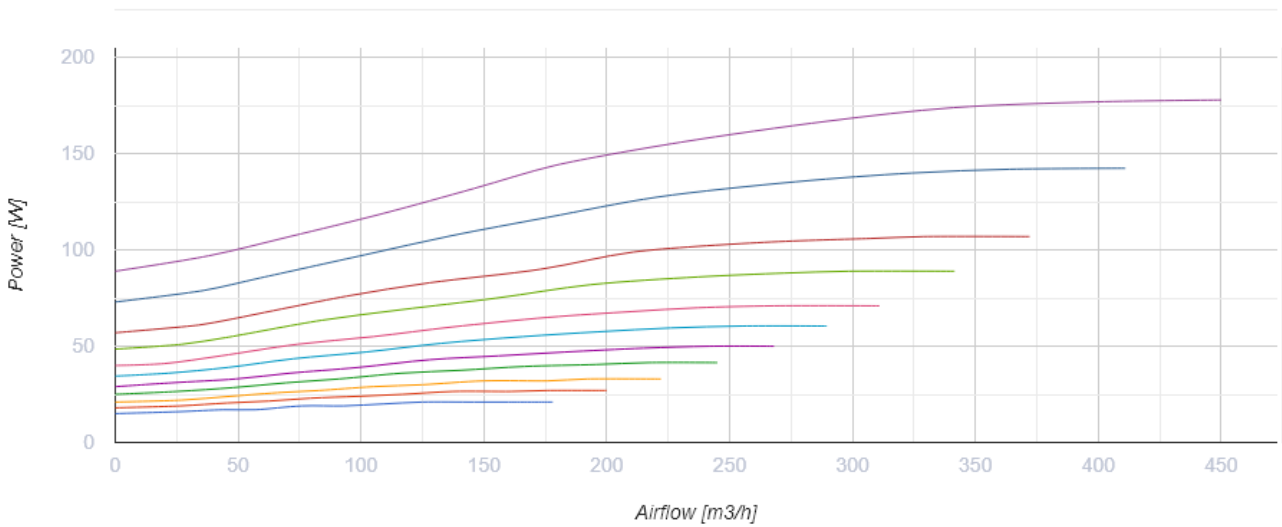
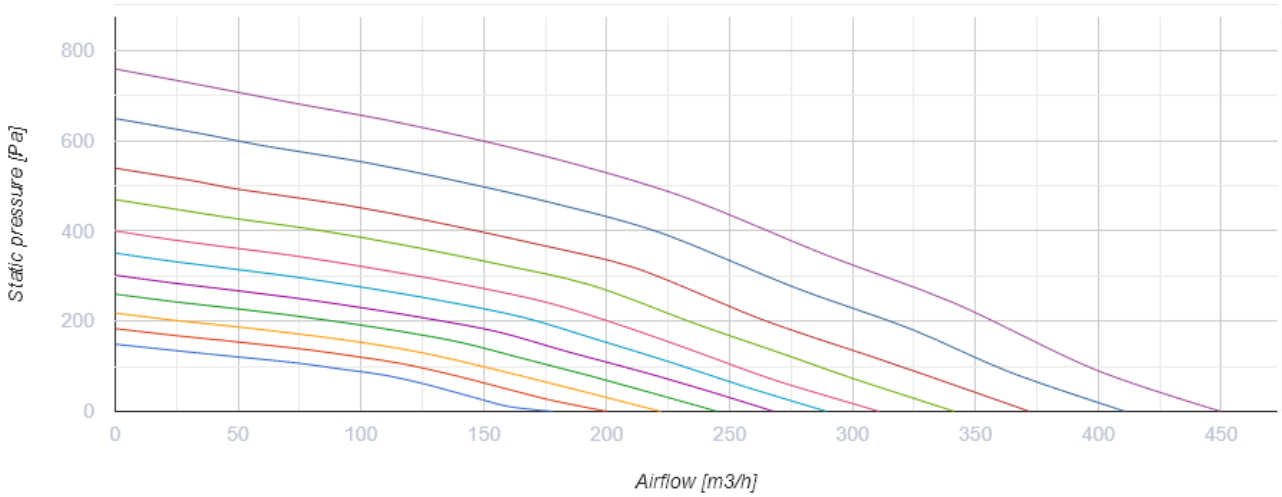

Dimensions

ØD	B	H	L
160	583	675	730



Ecodesign

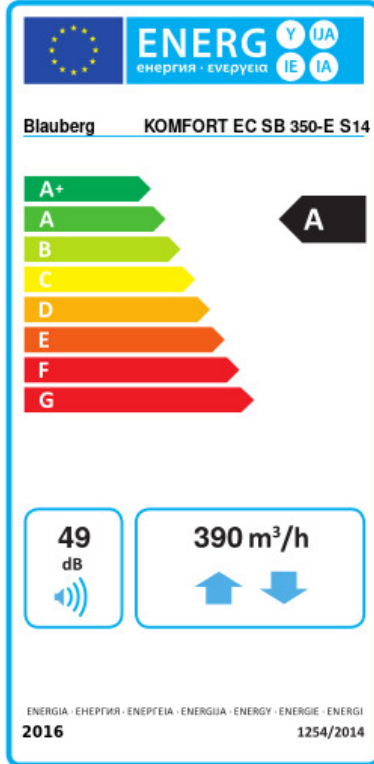

Trademark	Blauberg					
Model	KOMFORT EC SB 350-E S14					
Specific energy consumption (SEC) (kWh/(m ² /a))	Cold		Average		Warm	
	77	A+	40.2	A	16.6	E
Type of ventilation unit	Bidirectional					
Type of drive installed	Variable speed					
Type of heat recovery system	Recuperative					
Thermal efficiency of heat recovery (%)	76					
Maximum flow rate (m ³ /h)	390					
Electric power input (W)	177					
Reference flow rate (m ³ /s)	0.078					
Reference pressure difference (Pa)	50					
Specific power input (SPI) (W/(m ³ /h))	0.254					
Control typology	Local demand control					
Maximum internal leakage rates (%)	2.7					
Maximum external leakage rates (%)	2.7					
Declared typology	RVU BVU					
Sound power level (dB(A))	49					
The annual electricity consumption (AEC) (kWh/a)	Cold		Average		Warm	
	716		179		134	
The annual heating saved (AHS) (kWh/a)	Cold		Average		Warm	
	8614		4403		1991	