

# KOMFORT Ultra L3 250 S3 white

## Compact heat recovery air handling units

### Features

- Air handling units for efficient supply and exhaust ventilation in flats, houses, cottages and other buildings.
- Heat and humidity recovery reduces ventilation heat losses in the cold season and the load on the air conditioners in the hot season.
- Control of air exchange for creating comfortable indoor microclimate.
- Compatible with round Ø 125 mm air ducts.



**Air flow:**  
up to 290 m<sup>3</sup>/h  
81 l/s



**Heat recovery efficiency:**  
up to 73 %



### Design

- The casing of the unit is made of double skinned white painted metal panels, internally filled with 20 mm mineral wool layer for heat- and sound insulation.
- The spigots for connection to the air ducts are located at the side of the unit.
- The hinged panel of the casing ensures easy access to the unit internals for service works including cleaning, filter replacement, etc.

### Fans

- Asynchronous external rotor motors and centrifugal impellers with backward curved blades are used for air supply and exhaust.
- Integrated motor overheating protection with automatic restart.
- Dynamically balanced impellers.
- Equipped with ball bearings for longer service life.
- Reliable and quiet operation.

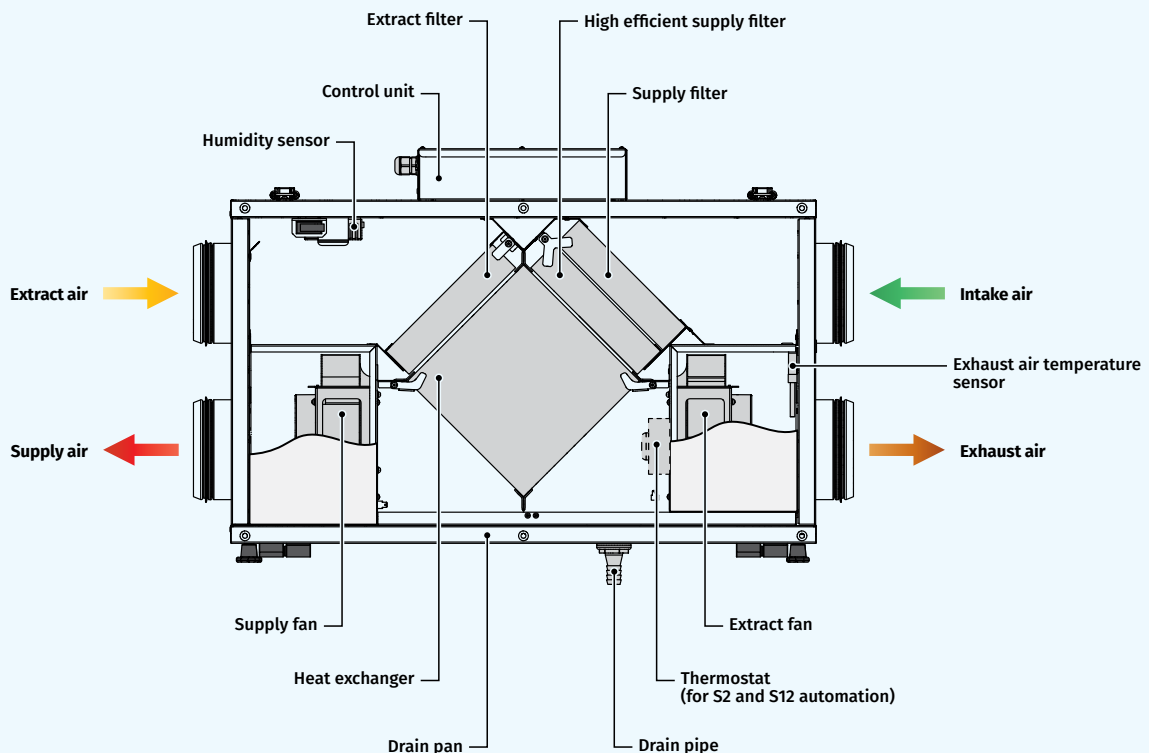

### Heat Recovery

- The **KOMFORT Ultra L3 250-E S3 white** unit is equipped with a plate enthalpy cross-flow heat exchanger made of polymerized cellulose that recovers heat and humidity.
- Due to humidity recovery the enthalpy heat exchanger produces no condensate.



- The air flows are fully separated within the heat exchangers. Odours and contaminants contained in the extract air are not transferred to the supply air flow.
- Heat recovery is based on heat and/or humidity transfer through the plates of the heat exchanger. In the cold season supply air is heated in the heat exchanger by transferring the heat energy of warm and humid extract air to the cold fresh air. Heat recovery minimizes heat losses, which reduces the cost of space heating.
- In summer the heat exchanger performs reverse and intake air is cooled in the heat exchanger by the cooled extract air. This reduces load on air conditioners and saves electricity.
- In summer, when the indoor and outdoor temperature difference is low heat recovery is not reasonable. In this case the heat exchanger can be temporarily replaced with a summer block for warm seasons (available separately).

### Air Filtration

- Two built-in G4 and F8 filters provide efficient supply air filtration.
- The G4 filter is used for extract air filtration.

### Control and Automation

- Turning the unit on/off from the control panel.
- Selecting ventilation mode – three speeds: minimum, medium, maximum.
- Freeze protection of the heat exchanger by means of turning off the supply fan during defrosting.



### Mounting

- The units can be fixed to the wall, ceiling or mounted on the floor using the mounting brackets.
- While mounting provide free access to the service panel for filter replacement and servicing.
- Due to universal casing design both left and right mounting is possible. It requires swapping the service and the back panel.

Designation key							
Serie	Unit type	Spigot modification	Modification	Rated air flow [m³/h]	Heat exchanger type	Control	Casing
KOMFORT	<b>Ultra:</b> compact unit	L: horizontal spigot orientation	3	250	– E: energy recovery	S3: multi speed switch	<b>white:</b> painted steel

### Overall Dimensions [mm]

Model	D	B	H	H1	L	L1
KOMFORT Ultra L3 250-E S3 white	125	300	443	43	713	810

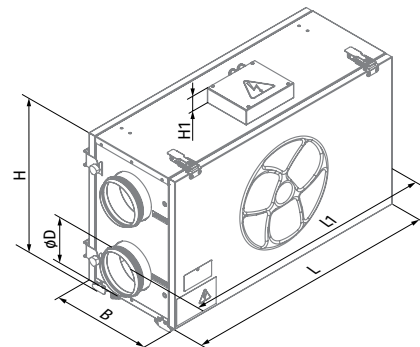

### Ordering Information





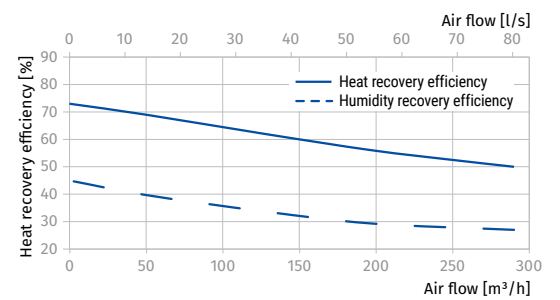
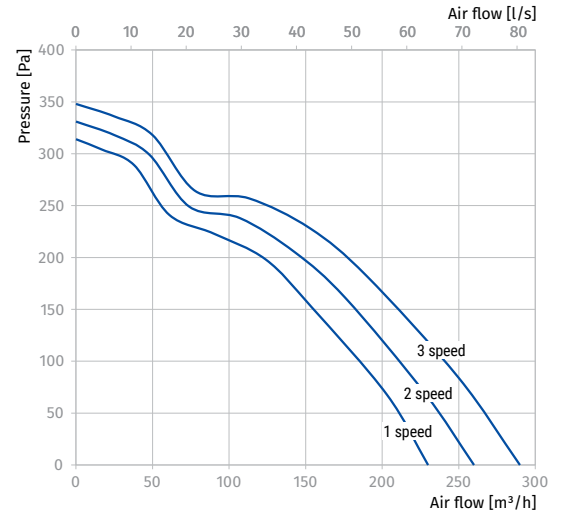

Part Number	Model	Description
BLAKOMFORTULTRAL3250-ES3	KOMFORT Ultra L3 250-E S3 white	WALL/FLOOR MOUNTED COMPACT ENERGY AHU

## Technical Data

Parameters	KOMFORT Ultra L3 250-E S3 white
Voltage [V/50 (60) Hz]	1 ~ 220-240
Power [W]	176
Current [A]	0.8
Maximum air flow [m <sup>3</sup> /h (l/s)]	290 (81)
RPM [min <sup>-1</sup> ]	1550
Sound pressure level at 3 m [dBA]	28-47
Transported air temperature [°C]	-25...+60
Insulation	20 mm, mineral wool
Extract filter	G4
Supply filter	F8+G4
Connected air duct diameter [mm]	125
Heat recovery efficiency [%]	50-73
Humidity recovery efficiency [%]	27-45
Heat exchanger type	cross-flow
Heat exchanger material	polymerized cellulose



**Accessories**

		KOMFORT Ultra L3 250-E S3 white
G4 panel filter		FP 240x184x40 G4
F8 panel filter		FP 240x184x40 F8
Silencer		SD 125
Silencer		SDF 125
Backdraft air damper		VRV 125
Air damper		VK 125
Summer block		SB C4 200/240