



AIR HANDLING UNIT

Freshbox 200 ERV WiFi
Freshbox E-200 ERV WiFi
Freshbox E1-200 ERV WiFi
Freshbox E2-200 ERV WiFi

EN

USER'S MANUAL

CONTENTS

Safety requirements.....	2
Purpose.....	4
Delivery set.....	4
Designation key.....	4
Technical data.....	5
Design and operating principle	7
Mounting and set-up.....	9
Connection to power mains	12
Control	13
Technical maintenance.....	17
Troubleshooting.....	18
Storage and transportation regulations.....	18
Manufacturer's warranty	19
Certificate of acceptance.....	23
Seller information	23
Installation certificate.....	23
Warranty card.....	23

This user's manual is a main operating document intended for technical, maintenance, and operating staff.

The manual contains information about purpose, technical details, operating principle, design, and installation of the Freshbox (E)/(E1)/(E2)-200 ERV WiFi unit and all its modifications.

Technical and maintenance staff must have theoretical and practical training in the field of ventilation systems and should be able to work in accordance with workplace safety rules as well as construction norms and standards applicable in the territory of the country.

SAFETY REQUIREMENTS

This unit is not intended for use by persons (including children) with reduced physical, sensory or mental capabilities, or lack of experience and knowledge, unless they have been given supervision or instruction concerning use of the unit by a person responsible for their safety. Children should be supervised to ensure that they do not play with the unit.

This appliance can be used by children aged from 8 years and above and persons with reduced physical, sensory or mental capabilities or lack of experience and knowledge if they have been given supervision or instruction concerning use of the appliance in a safe way and understand the hazards involved.

Cleaning and user maintenance shall not be made by children without supervision.

Children shall not play with the appliance.

Connection to the mains must be made through a disconnecting device, which is integrated into the fixed wiring system in accordance with the wiring rules for design of electrical units, and has a contact separation in all poles that allows for full disconnection under overvoltage category III conditions.

Ensure that the unit is switched off from the supply mains before removing the guard.

Precautions must be taken to avoid the back-flow of gases into the room from the open flue of gas or other fuel-burning appliances.

The appliance may adversely affect the safe operation of appliances burning gas or other fuels (including those in other rooms) due to back flow of combustion gases. These gases can

potentially result in carbon monoxide poisoning. After installation of the unit the operation of flued gas appliances should be tested by a competent person to ensure that back flow of combustion gases does not occur.

All operations described in this manual must be performed by qualified personnel only, properly trained and qualified to install, make electrical connections and maintain ventilation units.

Do not attempt to install the product, connect it to the mains, or perform maintenance yourself. This is unsafe and impossible without special knowledge.

Disconnect the power supply prior to any operations with the unit.

All user's manual requirements as well as the provisions of all the applicable local and national construction, electrical, and technical norms and standards must be observed when installing and operating the unit.

Disconnect the unit from the power supply prior to any connection, servicing, maintenance, and repair operations.

Connection of the unit to power mains is allowed by a qualified electrician with a work permit for the electric units up to 1000 V after careful reading of the present user's manual.

Check the unit for any visible damage of the impeller, the casing, and the grille before starting installation. The casing internals must be free of any foreign objects that can damage the impeller blades.

While mounting the unit, avoid compression of the casing! Deformation of the casing may result in motor jam and excessive noise.

Misuse of the unit and any unauthorised modifications are not allowed.

Do not expose the unit to adverse atmospheric agents (rain, sun, etc.).

Transported air must not contain any dust or other solid impurities, sticky substances, or fibrous materials.

Do not use the unit in a hazardous or explosive environment containing spirits, gasoline, insecticides, etc.

Do not close or block the intake or extract vents in order to ensure the efficient air flow.

Do not sit on the unit and do not put objects on it.

The information in this user's manual was correct at the time of the document's preparation.

The Company reserves the right to modify the technical characteristics, design, or configuration of its products at any time in order to incorporate the latest technological developments.

Never touch the unit with wet or damp hands.

Never touch the unit when barefoot.

BEFORE INSTALLING ADDITIONAL EXTERNAL DEVICES, READ THE RELEVANT USER MANUALS.



THE PRODUCT MUST BE DISPOSED SEPARATELY AT THE END OF ITS SERVICE LIFE.

DO NOT DISPOSE THE UNIT AS UNSORTED DOMESTIC WASTE

PURPOSE

The unit is designed to ensure continuous mechanical air exchange in houses, offices, hotels, cafes, conference halls, and other utility and public spaces as well as to recover the heat energy contained in the air extracted from the premises to warm up the filtered stream of intake air.

The unit is not intended for organizing ventilation in swimming pools, saunas, greenhouses, summer gardens, and other spaces with high humidity.

Due to the ability to save heating energy by means of energy recovery, the unit is an important element of energy-efficient premises.

The unit is a component part and is not designed for stand-alone operation. It is rated for continuous operation.

Transported air must not contain any flammable or explosive mixtures, evaporation of chemicals, sticky substances, fibrous materials, coarse dust, soot and oil particles or environments favourable for the formation of hazardous substances (toxic substances, dust, pathogenic germs).

DELIVERY SET

NAME	NUMBER
Air handling unit	1 pc.
User's manual	1 pc.
Mounting template	1 pc.
Fastening kit	1 pc.
Magnetic sheet	1 pc.
Key	1 pc.
Spigot	1 pc.
Packing box	1 pc.

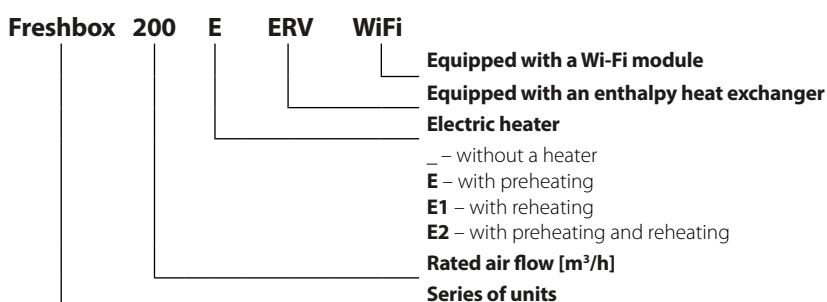
DESIGNATION KEY

TECHNICAL DATA

The unit is designed for indoor application with the ambient temperature ranging from +1 °C up to +40 °C and relative humidity up to 60 % without condensation. In cold, damp rooms, there is a possibility of freezing or condensation inside and outside the casing. In order to prevent condensation on the internal walls of the unit, it is necessary that the surface temperature of the casing is 2-3 °C above the dew point temperature of the transported air.

The unit should be operated continuously, and in cases where ventilation is not necessary, reduce the air flow of the fans to a minimum (20%). This will ensure a favorable indoor climate and reduce the amount of condensation inside the unit, which can damage electronic components. Never use the unit for dehumidification, for example, of new buildings.

The unit is rated as a Class I electrical appliance.

Hazardous parts access and water ingress protection rating:

IP22 for the unit connected to the air ducts

IP44 for the unit motors

The unit design is constantly being improved, thus some models may be slightly different from those described in this manual.

PARAMETER	FRESHBOX 200 ERV WIFI					FRESHBOX E-200 ERV WIFI					FRESHBOX E1-200 ERV WIFI					FRESHBOX E2-200 ERV WIFI				
	1	2	3	4	5	1	2	3	4	5	1	2	3	4	5	1	2	3	4	5
Speed																				
Unit voltage [V/50 (60) Hz]	1~230																			
Maximum unit power (without a heater) [W]	10	15	25	44	134	10	15	25	44	134	10	15	25	44	134	10	15	25	44	134
Preheater power [W]	-					650										650				
Reheater power [W]	-					-					700					700				
Maximum unit current [A]	1.0					4.0					4.2					7.2				
Max. air flow [m³/h]	30	60	90	120	200	30	60	90	120	200	30	60	90	120	200	30	60	90	120	200
Sound pressure level at 3 m distance [dBA]	12	22	30	36	45	12	22	30	36	45	12	22	30	36	45	12	22	30	36	45
Transported air temperature [°C]	-15...+40																			
Casing material	Painted steel																			
Insulation [mm]	30																			
Heat recovery efficiency [%]	85	81	75	68	66	85	81	75	68	66	85	81	75	68	66	85	81	75	68	66
Heat exchanger type	Counter-flow																			
Heat exchanger material	Enthalpy																			
Supply filter	G4 + F7 (H13 optional)																			
Extract filter	G4																			
Connected air duct diameter [mm]	100																			
Weight [kg]	55																			

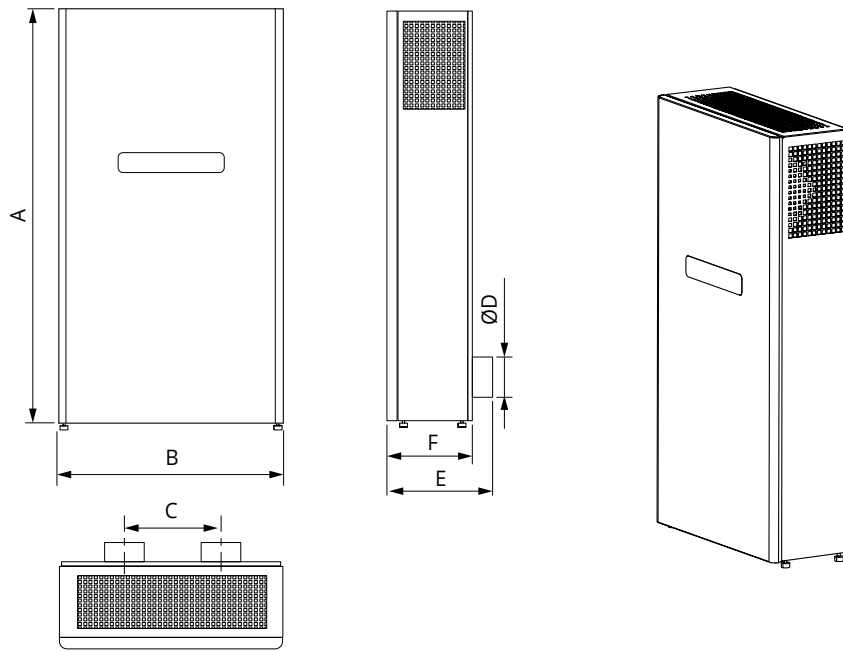

Model	Dimensions [mm]					
	Ø D	A	B	C	E	F
Freshbox(E)/(E1)/(E2)-200ERVWiFi	100	1020	550	240	265	214

DESIGN AND OPERATING PRINCIPLE

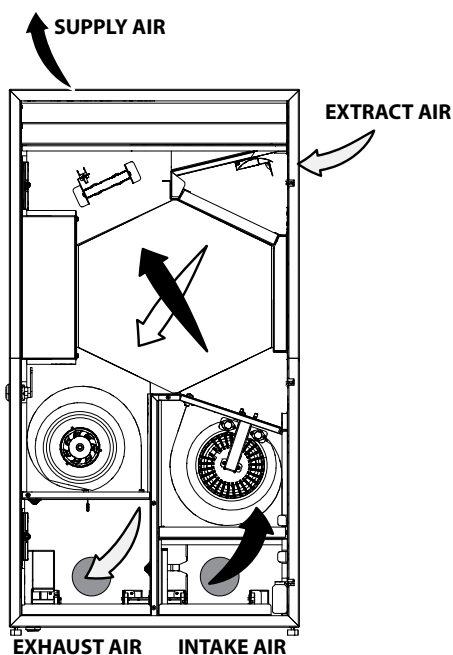
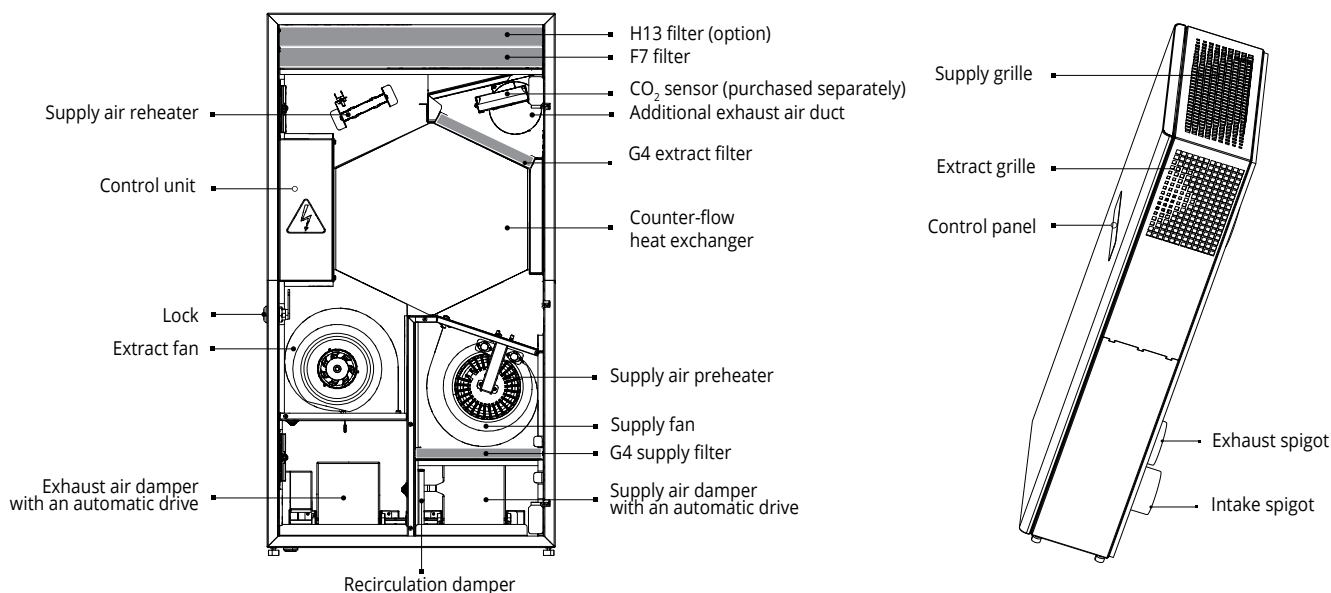

Warm stale extract air from the room flows to the unit, where it is filtered by the extract filter, then air flows through the heat exchanger and is exhausted outside by the extract fan. Cold fresh air from outside flows into the unit, where it is cleaned by the supply filter. Then filtered air flows through the heat exchanger and is moved to the room with the supply fan. Thermal energy of warm extract air is transferred to clean intake fresh air from outside and warms it up. The air flows are fully separated. Heat recovery minimizes heat losses, which reduces the cost of space heating in the cold season.

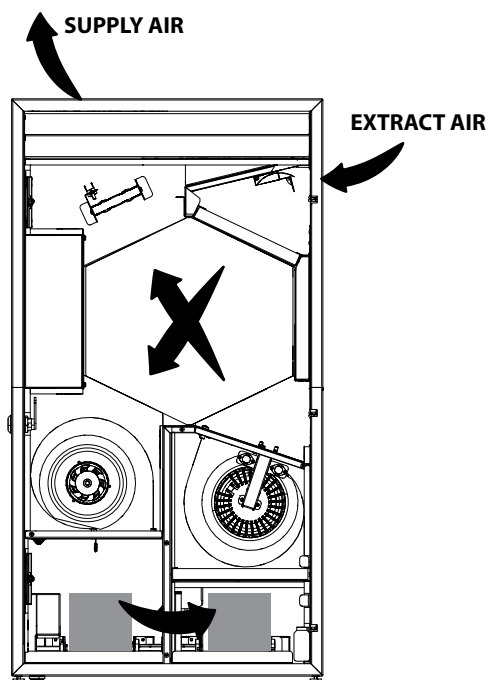

The unit is equipped with a recirculation damper. In recirculation mode it is opened and the supply and exhaust dampers are closed.

Air from the room passes through the filters, is purified again and is supplied back to the room with a heat exchanger. Depending on the model, the unit is equipped with a supply air preheater or post-heater with overheating protection.

The Freshbox E-200 ERV WiFi, Freshbox E2-200 ERV WiFi units are equipped with a preheater.

The preheater is located upstream of the heat exchanger and is designed for its overheating protection.

The Freshbox E1-200 ERV WiFi, Freshbox E2-200 ERV WiFi units are equipped with a reheater.

The reheater is located downstream of the heat exchanger and is designed for reheating the supply air to more comfortable temperature. When the intake air temperature is below $-3\text{ }^{\circ}\text{C}$, the preheater automatically warms up intake air so the average exhaust air temperature downstream of the heat exchanger is not below $+5\text{ }^{\circ}\text{C}$.

The reheater is switched on and off by means of a button on a sensor control panel, a remote control or via a mobile application.

The heat exchanger overheating protection in the Freshbox 200 ERV WiFi and Freshbox E1-200 ERV WiFi unit models without a preheater is achieved by automatic supply fan speed reduction according to extract air sensor readings.

The extract fan runs at maximum speed.

Condensate is not formed as units are equipped with an enthalpy heat exchanger and moisture is transferred from one air flow to another through a membrane.

The supply and exhaust air dampers open automatically when the motors are switched on and close when the motors are switched off.

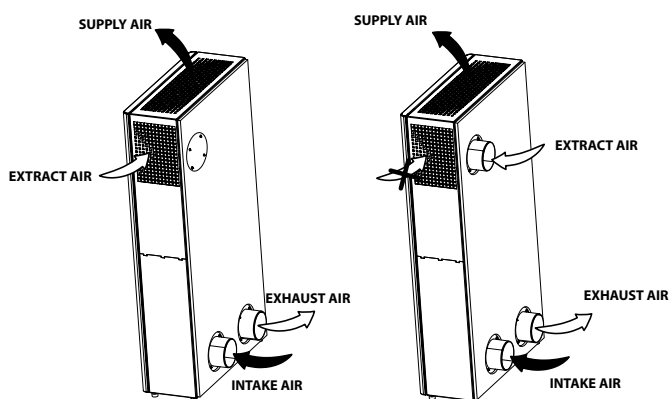

An additional extract spigot ($\varnothing 100\text{ mm}$) can be fitted to the unit to connect the exhaust air duct from additional premises, e.g. a bathroom. The spigot is included in the delivery set.

The exhaust grille must be closed with the magnetic plug included in the delivery set (see the "Mounting and set-up" section).

MOUNTING AND SET-UP



READ THE USER'S MANUAL BEFORE INSTALLING THE UNIT.



WHILE INSTALLING THE UNIT ENSURE CONVENIENT ACCESS FOR SUBSEQUENT MAINTENANCE AND REPAIR.



BEFORE MOUNTING MAKE SURE THE CASING DOES NOT CONTAIN ANY FOREIGN OBJECTS (E.G. FOIL, PAPER).



**THE UNIT MUST BE MOUNTED ON A PLANE SURFACE.
MOUNTING OF THE UNIT TO AN UNEVEN SURFACE CAN LEAD TO THE UNIT CASING DISTORTION AND OPERATION DISTURBANCE.**

When choosing the installation site, consider the minimum distances from the unit to the surfaces.

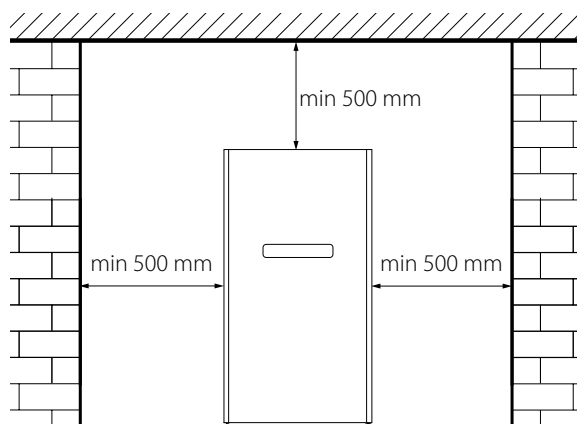

A mounting template is included in the delivery set.
Fix the mounting template at the required level on the wall.
Make marks to drill holes for air ducts, unit mounting and power cable entry.
Before installation operations begin, route necessary cables and wires to the unit mounting place.

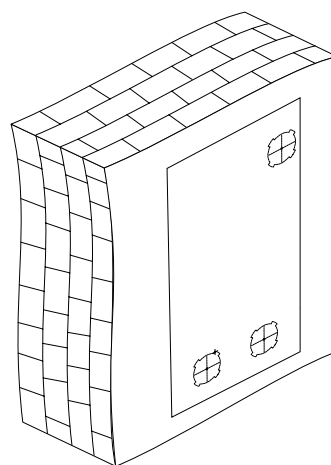

Remove the mounting template and drill two through holes \varnothing 120 mm for round air ducts.

When mounting the unit with an extract spigot, prepare a hole in the wall for a connecting bend and for laying of a rectangular air duct.

A connecting bend, rectangular and round air ducts are available separately.

Drill holes (\varnothing 8 mm, 90 mm deep) to mount the unit.

Install the expansion anchors, remove the perforated fillers for the air ducts from the mounting template and install the mounting template back.

Cut air ducts of required length. Note that the telescopic air duct end must protrude for the distance that enables installation of the outer ventilation hood (A). For details, refer to the installation instruction for the ventilation hood.

The outer ventilation hood is available separately.

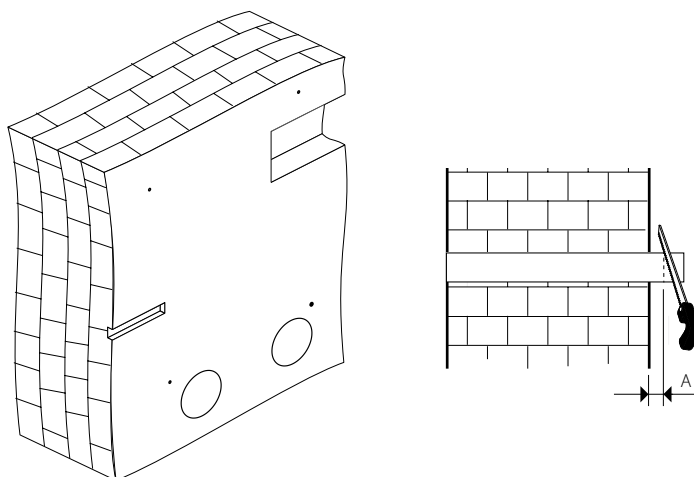

Insert the air ducts in the corresponding holes of the mounting template.

Install the air duct with the minimum slope of 3 mm for condensate removal.

To install the unit with an additional spigot insert the connecting bend into the prepared hole in the wall, aligning the mounting template hole with a round end of the connecting bend.

Connect a rectangular duct to the connecting bend.

Fill the gaps between the air ducts and the wall with a mounting foam.

Wait till the mounting foam hardens then take off the mounting template and remove the foam excess.

Cut off the protruding air duct parts to be flush with the wall surface.

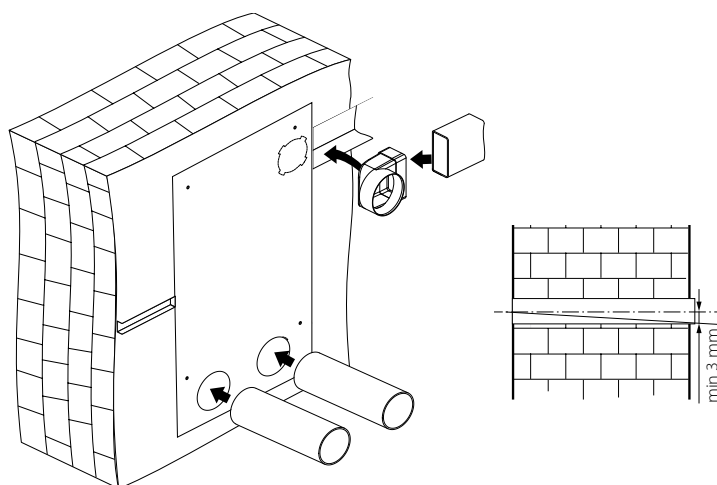

To install an extract spigot, remove the plug on the rear part of the unit.

Undo the screws, remove the plug and fix a spigot on its place using screws.

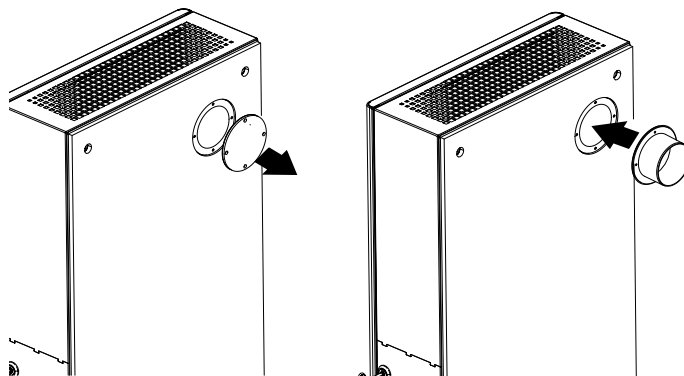

Open the unit.

Undo the screws and remove the protective panel for accessing the mounting holes.

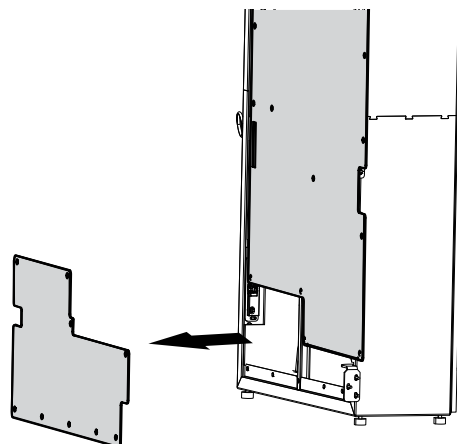

Remove the F7 and H13 filters for accessing the mounting holes.

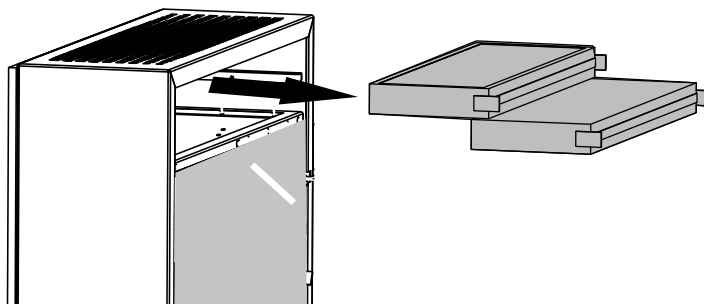

If an extract spigot is installed, remove the top protective panel and install the magnetic plug on the exhaust grille. When removing the panel, disconnect the grounding cable.

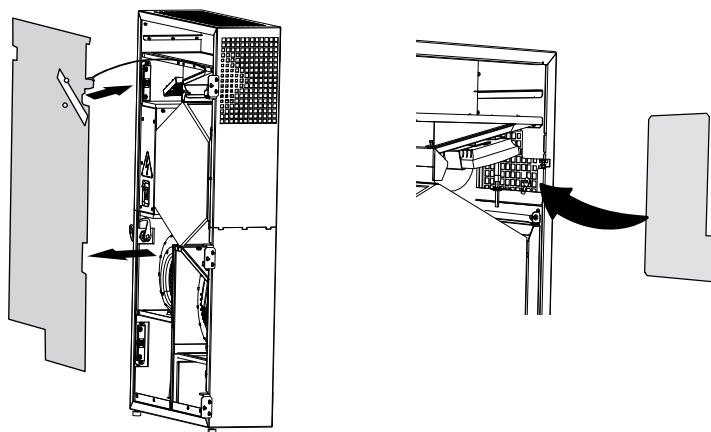

Lift the unit, insert the spigots into the corresponding air ducts installed in the wall.

The slope of the air ducts must be at least 3 mm.

Fix the unit using the supplied screws (included in the delivery set).

The unit is fastened with four screws.

Install the filters, the grounding cable and the protective panels back and close the unit door.

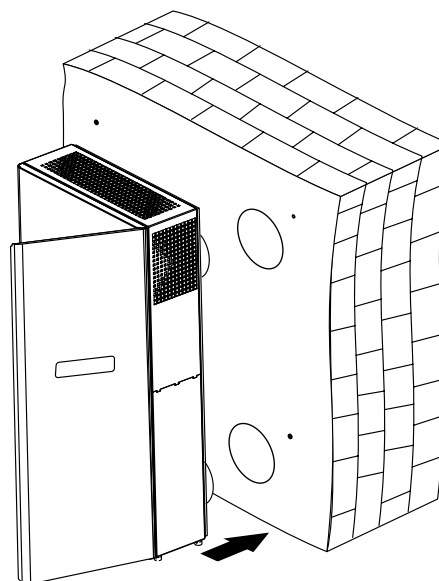

Install the outer ventilation hood:

- Remove the foam excess.
- Fill the gaps between the air ducts with sealant.
- Fix the outer hood on the outer wall of the building (see the ventilation hood installation manual).

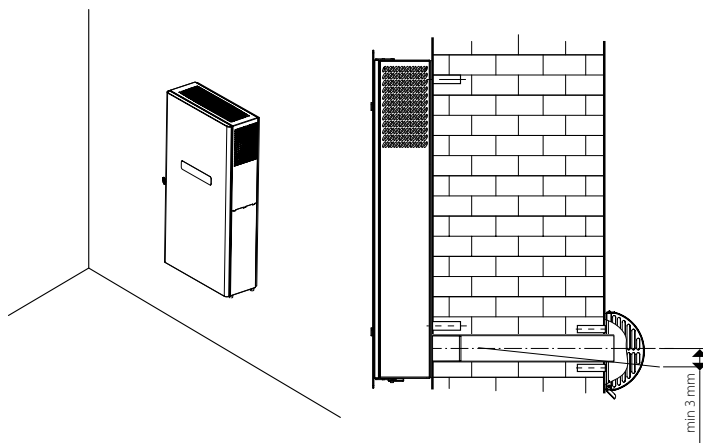

CONNECTION TO POWER MAINS



**POWER OFF THE POWER SUPPLY PRIOR TO ANY OPERATIONS WITH THE UNIT.
THE UNIT MUST BE CONNECTED TO POWER SUPPLY BY A QUALIFIED ELECTRICIAN.
THE RATED ELECTRICAL PARAMETERS OF THE UNIT ARE GIVEN ON THE
MANUFACTURER'S LABEL.**

- The unit is rated for connection to 1~230 V/50-60 Hz power mains.
- The unit must be connected to power mains using insulated electric conductors (cables, wires). The actual wire cross section selection must be based on the maximum load current, maximum conductor temperature depending on the wire type, insulation, length and installation method.
- The external power input must be equipped with an automatic circuit breaker built into the stationary wiring to open the electric circuit in case of overload or short-circuit. The circuit breaker installation place must provide quick access for emergency shutdown of the unit. The trip current of the automatic circuit breaker **QF** must exceed the maximum current consumption of the unit (refer to the technical data table). The recommended trip current of the circuit breaker is the next current in the standard trip current row following the maximum current of the connected unit. The automatic circuit breaker is not included in the delivery set.

Connection of unit contacts is carried out in the control unit.
To access the control unit, open the unit door, remove the protective panel, undo the screws securing the side wall, and remove it.

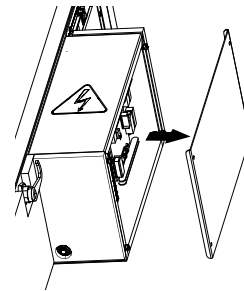

Connection of the automatic fire fighting system contact (PK)

In case of fire, the normally closed dry contact breaks the control circuit from the central fire-fighting board and cuts off power supply to the unit.

Connection of the contact for activating the Boost mode

The unit provides for the connection (parallel to the humidity sensor installed at the factory) of a normally open contact for activating the Boost mode. When the contact closes, the unit switches to maximum speed.

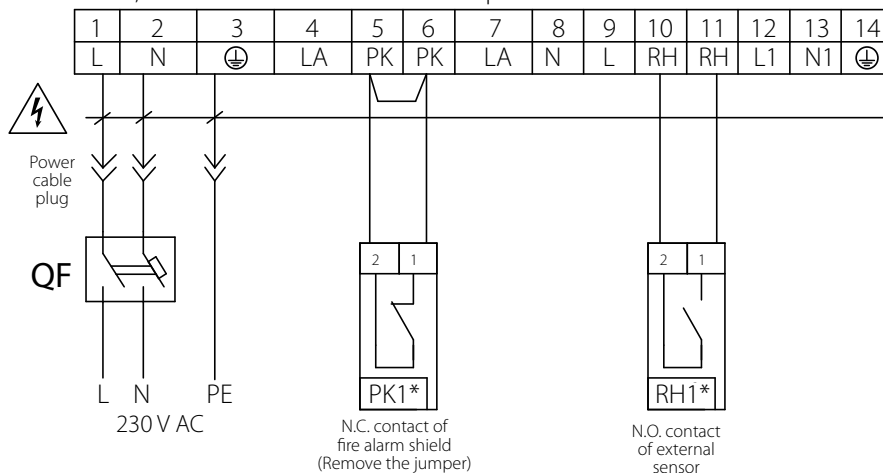

Designation	Name	Type	Cable
PK1*	Contact of fire alarm shield	N.C.	2x0.25 mm ²
RH1*	Contact of external sensor	N.O.	2x0.25 mm ²

 - Electric shock hazard!

* The unit is not included in the delivery set.

CONTROL



The unit is controlled by means of a control panel on the unit casing, a remote control or via a mobile application.

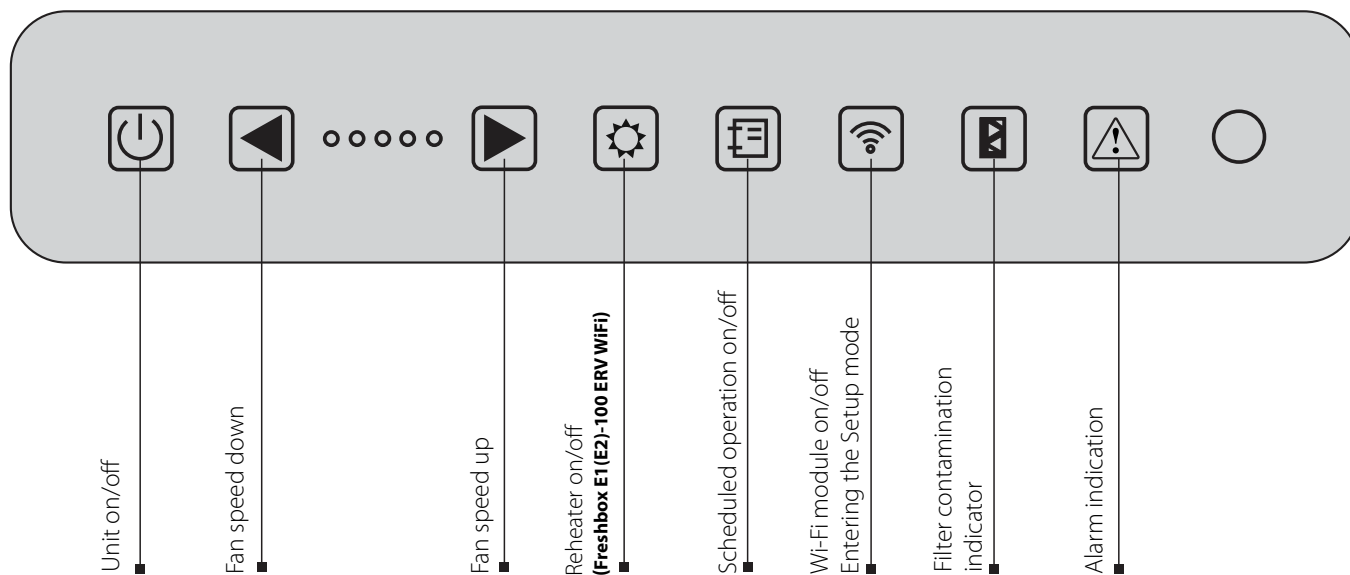

Control panel



1. The unit is switched on/off using .

2. Ventilation modes can be controlled by the  **and**  **buttons.**

The  and  buttons change the ventilation mode within five speeds.

Pressing  and  simultaneously for more than 3 seconds switches the timer on/off. The speed at which the unit operates after the timer activation and time are configured via the mobile application. The timer is configured via the mobile application (**air flow** and **time**).

3. The reheater is switched on/off using .

4. The weekly schedule can be switched on/off by pressing the  **button.**

For this mode, the time must be correctly set via the mobile application. By default, the controller stores a weekly schedule with factory settings. The button for switching on the weekly schedule blocks the buttons for changing speeds and switching the reheating on/off.

5. The Wi-Fi module is switched on/off using .

Switch the Wi-Fi module on/off by pressing . If the button is held down for more than 5 seconds, it flashes and the controller goes to the **Setup mode** (for more information on this mode, see page 15).

6. At the end of the filters' service life, the **filter replacement indicator**  on the control panel will light up notifying that filters need to be changed.

7. In emergency situations, the unit turns off and the  indicator flashes an alarm code.

Alarm code	Alarm description
— — — — —	Outside temperature sensor missing
— — — — .	Short circuit of the outside air temperature sensor
— — — . —	Sensor missing downstream of the reheater
— — — ..	Short circuit of the sensor downstream of the reheater
— — . — —	Extract air temperature sensor missing (upstream of the heat exchanger)
— — . — .	Short circuit of the exhaust air temperature sensor
— — .. —	Exhaust air temperature sensor missing (downstream of the heat exchanger)
— — ...	Short circuit of the sensor downstream of the heat exchanger in the exhaust air duct
— . — — —	Reserved
— . — — .	Reserved
— . — . —	Sensor missing downstream of the heat exchanger in the supply air duct
— . — ..	Short circuit of the sensor downstream of the heat exchanger in the supply air duct
— . . — —	Low battery. The weekly schedule function will not work correctly
—	Reserved
— . . . —	Fire alarm activation
—	Error of connection between the control panel and the controller (not indicated in the mobile application)
. — — — —	Wi-Fi module initialization error
.	Unknown error (if this error occurs, contact the customer service)

• – short light signal

— – long light signal

You may find a detailed alarm description in a mobile application.

Remote control

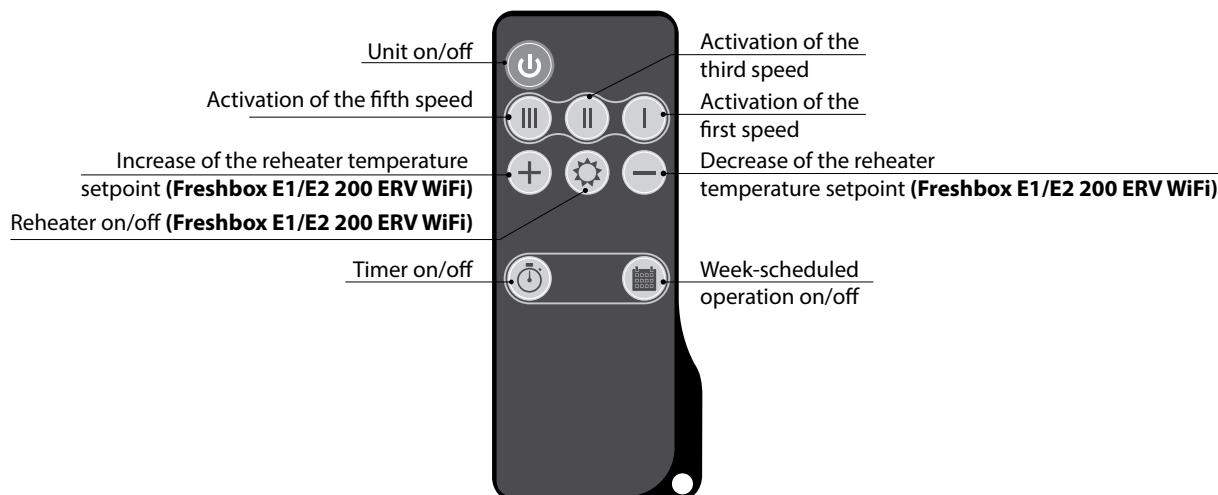

UNIT CONTROL VIA THE APPLICATION ON THE MOBILE DEVICE

Unit control is carried out using the **Blauberg Home** app on the mobile device.
The application is available for download at App Store, Play Market or via the QR code.

[Blauberg Home – App Store](#)



[Blauberg Home – Play Market](#)

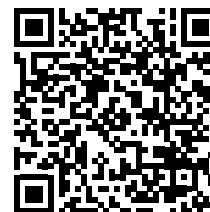

WI-FI TECHNICAL DATA

Standard	IEEE 802,11, b/g/n
Frequency band [GHz]	2,4
Transmission power [mW] (dBm)	100(+20)
Network	DHCP
WLAN safety	WPA, WPA2

By default, the unit operates as a Wi-Fi access point.

After installing the application, connect the mobile device to the unit as to a Wi-Fi access point (FAN: + 16 characters of the ID number) indicated on the control board and on the unit casing.

Wi-Fi access point password: 11111111 (eights ones).

The units can be controlled using the mobile app via a cloud server connection.

SPECIAL SETUP MODE

In the event of losing the Wi-Fi password or the unit password, connecting external devices or in other cases use the special Setup mode to restore access to the unit functions.

To enter the special Setup mode, press and hold the Wi-Fi button on the control panel for 5 seconds before the LED on the button starts flashing.

The unit will continue in this mode for 3 minutes and then will automatically revert to the previous settings.

To exit the Setup mode, press and hold the button again for 5 seconds until the LED on the button stops flashing.

Settings in the special Setup mode

Wi-Fi name: Setup mode.

Wi-Fi password: 11111111.

The unit password is ignored.

BASIC MODES

Boost mode: activated after sending a signal to the corresponding discrete input on the control circuit board. Has lower priority than **Timer** mode. There is a mode activation delay of 0 to 15 minutes (0 minutes by default) after the signal is sent to the digital input. There is also a mode deactivation delay of 0 to 60 minutes (0 minutes by default) after the signal on the digital input is lost. Air flow settings for supply and exhaust fans are available in the engineering menu (100% by default).

Timer mode: activated using a mobile app or remote control. Has higher priority than **Boost** and **Schedule** modes. This mode has duration, speed and temperature settings available.

Schedule mode: activated using a mobile app or remote control. Has the lowest priority. To set up a weekly schedule, there are 4 time intervals available for each day of the week. Duration of each time interval is configurable and both speed and temperature are selectable. Adjustment can be made separately for every day, weekdays, weekends or for the whole week. For the Schedule mode to work properly, make sure that the date and time are set correctly.

Filter

Filter timer setting is available. When the set time (70-365 days) has elapsed, the filter change indicator appears and filter replacement information is displayed in the Alarms menu. This timer can be turned off. If the unit is equipped with filter contamination pressure switches, after the timer is turned off filter contamination control will be carried out only by the pressure switches.

Air flow

This menu section enables setting the air flow values for the speed 1-5 pre-sets as well as the **Boost** mode..

Sensors

Boost switch. If this input is enabled, the Boost mode is activated on receiving a signal to this input (on).

Fire alarm sensor. Make sure that the fire alarm sensor is connected before enabling this input. A loss of signal at this input (off) triggers an alarm condition and causes the unit to shut down.

Main heater/preheater thermostat. If the respective heater is active, a loss of signal at these inputs (off) triggers an alarm condition and causes the AHU to shut down.

Alarm/Warning Codes

Ordering No.	Description
0	Alarm! Supply fan malfunction.
1	Alarm! Extract fan malfunction.
2	Alarm! Outdoor air temperature sensor missing.
3	Alarm! Short circuit of the outdoor temperature sensor.
4	Alarm! Supply air temperature sensor missing.
5	Alarm! Short circuit of the supply air temperature sensor.
6	Alarm! Extract air temperature sensor missing (upstream of the heat exchanger).
7	Alarm! Short circuit of the extract air temperature sensor (upstream of the heat exchanger).
8	Alarm! Exhaust air temperature sensor missing (downstream of the heat exchanger).
9	Alarm! Short circuit of the exhaust air temperature sensor (downstream of the heat exchanger).
10	Alarm! Actuation of the protecting pre-heater thermostat.
11	Alarm! Actuation of the main heater thermostat.
23	Warning! Low battery. The weekly schedule function will not work correctly
25	Alarm! Fire alarm activation.
40	Warning! The filter replacement timer has expired. The filter must be replaced.
50	Alarm! No connection between the control panel and the controller.
51	Alarm! Additional supply air temperature sensor missing upstream of the main heater.
52	Alarm! Short circuit of the additional supply air temperature sensor upstream of the heater.

TECHNICAL MAINTENANCE

Maintenance operations of the unit are required 3-4 times per year. Maintenance includes periodic dust removal from surfaces, cleaning or replacement of filters (if necessary) and dry cleaning of fans.

Maintenance includes general cleaning of the unit and the following operations:

1. Filter maintenance (3-4 times per year).

Dirty filters increase air resistance in the system and reduce supply air volume.

Remove the clogged filters from the unit.

- Clean the F7 filter with a vacuum cleaner.
- Clean the G4 filters with water and let them dry.

Install the filters back to the unit.

The filters require cleaning not less than 3-4 times per year.

For new filters, contact the Seller.

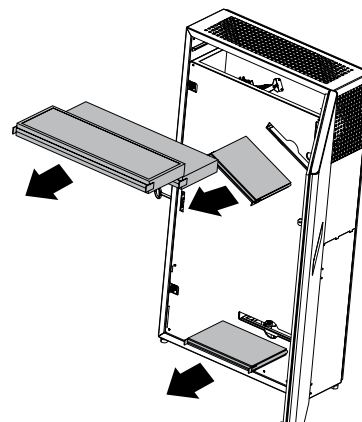

2. Heat exchanger maintenance (once a year).

Some dust may accumulate on the heat exchanger block even in case of regular maintenance of the filters.

To maintain the high heat recovery efficiency, regular cleaning is required.

Periodical dry cleaning is recommended. Use a vacuum cleaner with a narrow nozzle.

Remove the protective panels (see page 11).

Remove the clogged heat exchanger out of the unit, clean it with a vacuum cleaner and install the heat exchanger back to the unit.

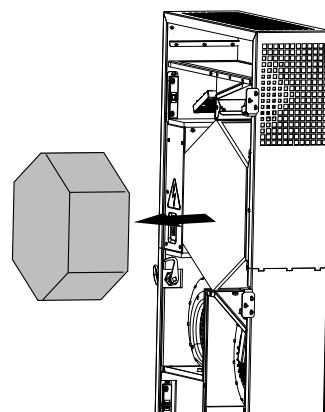

3. Fan maintenance (once a year).

Even in case of regular maintenance of the filters, some dust may accumulate inside the fans and reduce the fan performance and supply air flow.

Clean the fan with a cloth or a soft brush.

Do not use water, aggressive solvents, or sharp objects as they may damage the impeller. To access the supply fan, it is necessary to dismantle the electric heater (only in the Freshbox E-200 ERV WiFi and Freshbox E2-200 ERV WiFi models).

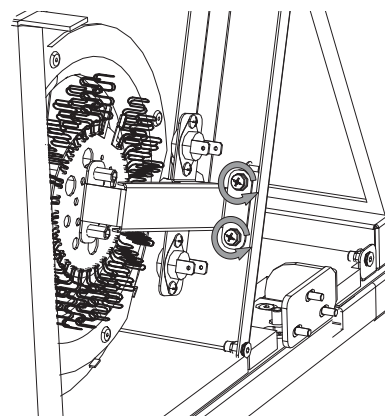

4. Technical maintenance of air duct system (every 5 years).

Even regular fulfilling of all the prescribed above maintenance operations may not completely prevent dirt accumulation in the air ducts which reduces the unit capacity. Duct maintenance means regular cleaning or replacement.

TROUBLESHOOTING

PROBLEM	POSSIBLE REASONS	TROUBLESHOOTING
The fan(s) do(es) not get started.	No power supply.	Make sure that the unit is properly connected to the power mains and make any corrections, if necessary.
Cold supply air.	Extract filter clogging.	Clean or replace the extract filter.
	Heat exchanger icing.	Check the heat exchanger for icing. Stop the unit operation if necessary and wait until the ice melts.
	Heater malfunction.	Contact the Seller.
Low air flow.	Filters, fans or the heat exchanger are soiled.	Clean or replace the filters, clean the fans and the heat exchanger.
	The ventilation system is soiled or damaged.	Check for unobstructed opening of diffusers and louver shutters, check the exhaust hood and the supply grille and clean those, if necessary. Make sure the air ducts are clean and intact.
Noise, vibration.	The fan impeller is soiled.	Clean the impellers.
	The screw connection is loose.	Tighten the fastening screws.

STORAGE AND TRANSPORTATION REGULATIONS

- Store the unit in the manufacturer's original packaging box in a dry closed ventilated premise with temperature range +5 ...+40 °C and relative humidity up to 70 %.
- Storage environment must not contain aggressive vapors and chemical mixtures provoking corrosion, insulation, and sealing deformation.
- Use suitable hoist machinery for handling and storage operations to prevent possible damage to the unit.
- Follow the handling requirements applicable for the particular type of cargo.
- The unit can be carried in the original packaging by any mode of transport provided proper protection against precipitation and mechanical damage. The unit must be transported only in the working position.
- Avoid sharp blows, scratches, or rough handling during loading and unloading.
- Prior to the initial power-up after transportation at low temperatures, allow the unit to warm up at operating temperature for at least 3-4 hours.

MANUFACTURER'S WARRANTY

The product is in compliance with EU norms and standards on low voltage guidelines and electromagnetic compatibility. We hereby declare that the product complies with the provisions of Electromagnetic Compatibility (EMC) Directive 2014/30/EU of the European Parliament and of the Council, Low Voltage Directive (LVD) 2014/35/EU of the European Parliament and of the Council and CE-marking Council Directive 93/68/EEC. This certificate is issued following test carried out on samples of the product referred to above.

The manufacturer hereby warrants normal operation of the unit for 24 months after the retail sale date provided the user's observance of the transportation, storage, installation, and operation regulations. Should any malfunctions occur in the course of the unit operation through the Manufacturer's fault during the guaranteed period of operation, the user is entitled to get all the faults eliminated by the manufacturer by means of warranty repair at the factory free of charge. The warranty repair includes work specific to elimination of faults in the unit operation to ensure its intended use by the user within the guaranteed period of operation. The faults are eliminated by means of replacement or repair of the unit components or a specific part of such unit component.

The warranty repair does not include:

- routine technical maintenance
- unit installation/dismantling
- unit setup

To benefit from warranty repair, the user must provide the unit, the user's manual with the purchase date stamp, and the payment paperwork certifying the purchase. The unit model must comply with the one stated in the user's manual. Contact the Seller for warranty service.

The manufacturer's warranty does not apply to the following cases:

- User's failure to submit the unit with the entire delivery package as stated in the user's manual including submission with missing component parts previously dismantled by the user.
- Mismatch of the unit model and the brand name with the information stated on the unit packaging and in the user's manual.
- User's failure to ensure timely technical maintenance of the unit.
- External damage to the unit casing (excluding external modifications as required for installation) and internal components caused by the user.
- Redesign or engineering changes to the unit.
- Replacement and use of any assemblies, parts and components not approved by the manufacturer.
- Unit misuse.
- Violation of the unit installation regulations by the user.
- Violation of the unit control regulations by the user.
- Unit connection to power mains with a voltage different from the one stated in the user's manual.
- Unit breakdown due to voltage surges in power mains.
- Discretionary repair of the unit by the user.
- Unit repair by any persons without the manufacturer's authorization.
- Expiration of the unit warranty period.
- Violation of the unit transportation regulations by the user.
- Violation of the unit storage regulations by the user.
- Wrongful actions against the unit committed by third parties.
- Unit breakdown due to circumstances of insuperable force (fire, flood, earthquake, war, hostilities of any kind, blockades).
- Missing seals if provided by the user's manual.
- Failure to submit the user's manual with the unit purchase date stamp.
- Missing payment paperwork certifying the unit purchase.



FOLLOWING THE REGULATIONS STIPULATED HEREIN WILL ENSURE A LONG AND TROUBLE-FREE OPERATION OF THE UNIT



USER'S WARRANTY CLAIMS SHALL BE SUBJECT TO REVIEW ONLY UPON PRESENTATION OF THE UNIT, THE PAYMENT DOCUMENT AND THE USER'S MANUAL WITH THE PURCHASE DATE STAMP

CERTIFICATE OF ACCEPTANCE

Unit Type	Air handling unit
Model	
Serial Number	
Manufacture Date	
Quality Inspector's Stamp	

SELLER INFORMATION

Seller	
Address	
Phone Number	
E-mail	
Purchase Date	
This is to certify acceptance of the complete unit delivery with the user's manual. The warranty terms are acknowledged and accepted.	
Customer's Signature	

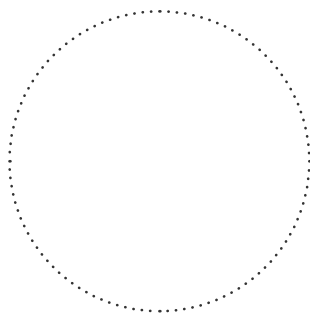

Seller's Stamp

INSTALLATION CERTIFICATE

The _____ unit is installed pursuant to the requirements stated in the present user's manual.	
Company name	
Address	
Phone Number	
Installation Technician's Full Name	
Installation Date:	Signature:
The unit has been installed in accordance with the provisions of all the applicable local and national construction, electrical and technical codes and standards. The unit operates normally as intended by the manufacturer.	
Signature:	

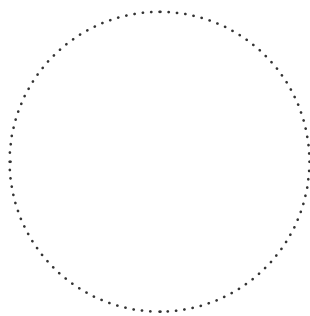

Installation Stamp

WARRANTY CARD

Unit Type	Air handling unit
Model	
Serial Number	
Manufacture Date	
Purchase Date	
Warranty Period	
Seller	

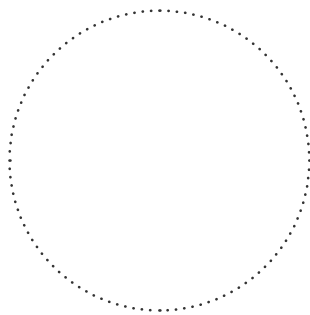

Seller's Stamp

