

BLA907N

Header Box Fan

Features

- The Blauberg **BLA907N** offers superior performance in header box fan design with superior performance, low height profile, low noise, good airflow and high pressure.
- Blauberg header box fans are designed for contractors and developers who are looking for quality header box fans with good performance and fast efficient installation times.
- Extraction of air from bathrooms, kitchens, ensuites, toilets, laundries and apartments.



Design

- Centrifugal side discharge fan, low noise and backdraft damper, made from high quality ABS plastic housing with an injection moulded plastic pure white grille.

Motor

- 240 V single phase at 50 Hz. All motors have a sealed NSK ball bearing motor with a service life of up to 20,000 hours and come with a thermal overload fuse that cannot be reset.

Wiring

- 1.0 m lead and 2 pin plug.

Ordering Information

| Part Number | Description |
|-------------|--|
| BLA907N | Header Box Fan with 100 mm / 150 mm Side Duct Outlet |

Overall Dimensions [mm]

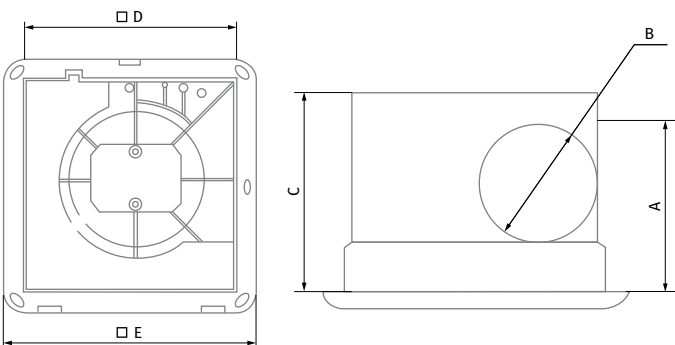

| Model | A | B | C | D | E |
|---------|-----|---------|-----|-----|-----|
| BLA907N | 140 | 100/150 | 165 | 260 | 300 |

Mounting

- Quick install screw down clips that lock down onto the ceiling provide a fast installation process and a tidy finish, with a clip mounted grille providing a tight secure fit to the ceiling.



Technical Data

| Model | BLA907N |
|-----------------------------|-------------|
| Voltage [V/Hz] | 220-240/50 |
| Power [W] | 24 |
| Extract capacity [m³/h] | 162 |
| Noise level [dBA] | 38 |
| RPM [min ⁻¹] | 2050 |
| Installation type | Ceiling |
| Installation position | Ceiling |
| DN (diameter nominal) [mm] | 100 |
| Air flow temperature [°C] | -10 ... +45 |
| Index of protection | IP24 |
| Internal thermal protection | Fuse |
| Casting material | ABS plastic |

