



AXIAL WALL / CEILING FAN

BLABAERO 100, 125, 150, 100T, 150T

USER'S MANUAL



EN

CONTENTS

Safety requirements.....	3
Delivery set.....	8
Brief description.....	8
Operation guidelines.....	8
Mounting and set-up.....	9
Technical maintenance.....	10
Troubleshooting.....	11
Storage and transportation regulations.....	11
Manufacturer's warranty.....	12

This user's manual is a main operating document intended for technical, maintenance, and operating staff.

The manual contains information about purpose, technical details, operating principle, design, and installation of the BLABAERO unit and all its modifications.

Technical and maintenance staff must have theoretical and practical training in the field of ventilation systems and should be able to work in accordance with workplace safety rules as well as construction norms and standards applicable in the territory of the country.



**READ THE USER'S MANUAL CAREFULLY BEFORE PROCEEDING WITH INSTALLATION WORKS.
COMPLIANCE WITH THE MANUAL REQUIREMENTS ENSURES RELIABLE OPERATION AND LONG
SERVICE LIFE OF THE UNIT.
KEEP THE USER'S MANUAL AVAILABLE AS LONG AS YOU USE THE UNIT. YOU MAY NEED TO
REREAD THE INFORMATION ON THE PRODUCT SERVICING.**



FOLLOW THE USER'S MANUAL REQUIREMENTS TO ENSURE DURABLE AND TROUBLE-FREE OPERATION OF THE UNIT

SAFETY REQUIREMENTS

All operations described in this manual must be performed by qualified personnel only, properly trained and qualified to install, make electrical connections and maintain ventilation units.

Do not attempt to install the product, connect it to the mains, or perform maintenance yourself.

This is unsafe and impossible without special knowledge.

Disconnect the power supply prior to any operations with the unit.

All user's manual requirements as well as the provisions of all the applicable local and national construction, electrical, and technical norms and standards must be observed when installing and operating the unit.

Disconnect the unit from the power supply prior to any connection, servicing, maintenance, and repair operations.

Connection of the unit to power mains is allowed by a qualified electrician with a work permit for the electric units up to 1000 V after careful reading of the present user's manual.

Check the unit for any visible damage of the impeller, the casing, and the grille before starting installation. The casing internals must be free of any foreign objects that can damage the impeller blades.

While mounting the unit, avoid compression of the casing!

Deformation of the casing may result in motor jam and excessive noise.

Misuse of the unit and any unauthorised modifications are not allowed.

Do not expose the unit to adverse atmospheric agents (rain, sun, etc.).

Transported air must not contain any dust or other solid impurities, sticky substances, or fibrous materials.

Do not use the unit in a hazardous or explosive environment containing spirits, gasoline, insecticides, etc.

Do not close or block the intake or extract vents in order to ensure the efficient air flow.

Do not sit on the unit and do not put objects on it.

The information in this user's manual was correct at the time of the document's preparation.

The Company reserves the right to modify the technical characteristics, design, or configuration of its products at any time in order to incorporate the latest technological developments.

Never touch the unit with wet or damp hands.

Never touch the unit when barefoot.

BEFORE INSTALLING ADDITIONAL EXTERNAL DEVICES, READ THE RELEVANT USER MANUALS.

This unit is not intended for use by persons (including children) with reduced physical, sensory or mental capabilities, or lack of experience and knowledge, unless they have been given supervision or instruction concerning use of the unit by a person responsible for their safety.

Children should be supervised to ensure that they do not play with the unit.

Precautions must be taken to avoid the back-flow of gases into the room from the open flue of gas or other fuel-burning appliances.

The appliance may adversely affect the safe operation of appliances burning gas or other fuels (including those in other rooms) due to back flow of combustion gases. These gases can potentially result in carbon monoxide poisoning. After installation of the unit the operation of flued gas appliances should be tested by a competent person to ensure that back flow of combustion gases does not occur.



**THE PRODUCT MUST BE DISPOSED SEPARATELY AT THE END OF ITS SERVICE LIFE.
DO NOT DISPOSE THE UNIT AS UNSORTED DOMESTIC WASTE.**

DELIVERY SET

Fan – 1 pc.

Screws and dowels – 4 pcs.

Plastic screwdriver (for the models with a timer) – 1 pc.

User's manual – 1 pc.

Packing box – 1 pc.

BRIEF DESCRIPTION

The unit described herein is an axial fan for exhaust ventilation of small to medium-sized premises heated during winter. It is designed for wall or ceiling mounting (Fig. 1-3). The fan is designed for connection to \varnothing 100, 125 and 150 mm air ducts.

OPERATION GUIDELINES

The fan is rated for connection to single-phase AC 220-240 V/50 Hz power mains.

Air motion direction in the system must match the pointer on the fan casing.

Hazardous parts access and water ingress protection rating is IP22.

The fan is rated for operation at the ambient temperature ranging from +1 °C up to +45 °C.

The unit is rated as a Class II electrical appliance.

MOUNTING AND SET-UP

The fan is designed for wall or ceiling mounting with direct air exhaust to the ventilation shaft or into the round air duct of matching diameter.

The fan mounting sequence is shown in fig. 6-9. The fan wiring diagrams are shown in fig. 10.

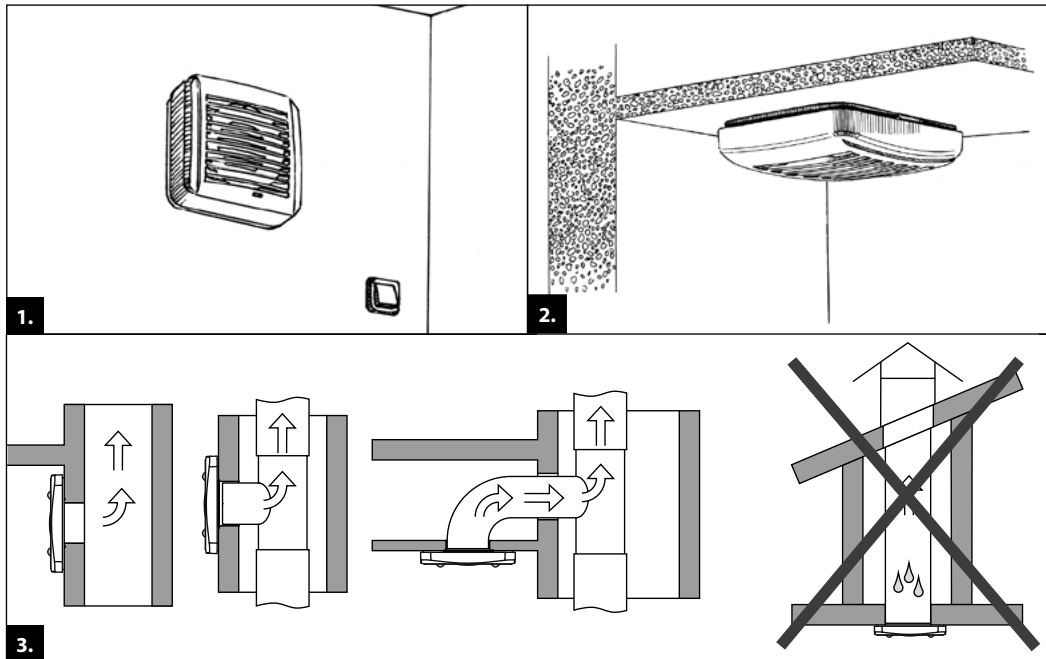

TECHNICAL MAINTENANCE

The fan maintenance periodicity is at least once per 6 months.

Maintenance steps:

- Disconnect the fan from power supply and take steps to avoid unauthorized power supply connection (Fig. 11).
- Remove the decorative panels, wipe the fan with a dry cloth or a brush (Fig. 12).
- Clean the front panel under running water (Fig. 13).
- Wipe the fan surfaces dry.
- Cover the fan with the front panel.
- Connect power supply to the fan (Fig. 14).

WARNING! Do not allow water or liquid come into contact with electric components!

TROUBLESHOOTING

Problem	Possible reasons	Troubleshooting
When the unit is connected to power mains, the fan does not rotate and does not respond to any controls.	No power supply.	Make sure the power supply line is connected correctly, otherwise troubleshoot the connection error.
	Internal connection fault.	Contact the Seller.
Low air flow.	The ventilation system is clogged.	Clean the ventilation system.
Increased noise, vibration.	The impeller is clogged.	Clean the impeller.
	The fan is not secured well or is not mounted properly.	Troubleshoot the installation error.
	The ventilation system is clogged.	Clean the ventilation system.

STORAGE AND TRANSPORTATION REGULATIONS

- Store the unit in the manufacturer's original packaging box in a dry closed ventilated premise with temperature range from +5 °C to +40 °C and relative humidity up to 70 %.
- Storage environment must not contain aggressive vapors and chemical mixtures provoking corrosion, insulation, and sealing deformation.
- Use suitable hoist machinery for handling and storage operations to prevent possible damage to the unit.
- Follow the handling requirements applicable for the particular type of cargo.
- The unit can be carried in the original packaging by any mode of transport provided proper protection against precipitation and mechanical damage. The unit must be transported only in the working position.
- Avoid sharp blows, scratches, or rough handling during loading and unloading.
- Prior to the initial power-up after transportation at low temperatures, allow the unit to warm up at operating temperature for at least 3-4 hours.

MANUFACTURER'S WARRANTY

Blauberg Warranty:

- This warranty is given by Blauberg Australasia Pty Ltd, with an office at Unit 5, 45A Eastern Creek Drive, Eastern Creek, New South Wales 2766, Australia. Phone 1300 475-504.
- From the date of purchase, the original purchaser is entitled to free replacement parts, or a new unit for a period of 60 months years from the date of purchase.
- The defective parts or unit must be returned to Blauberg Australasia Pty Ltd at your own cost before an exchange or parts or unit will be given.
- A proof of purchase will be required before a warranty claim is accepted.
- The warranty will also not cover damage caused by misuse, neglect, shipping accident, incorrect or improper installation, voltage supply problems, unauthorised modification or repairs of any kind, exposure to corrosive conditions, exposure to weather and where no fault is found with the product.
- We will not cover any loss incurred by you in relation to the product or making the claim under this warranty including without limitation any costs associated with installation, reinstallation, or transporting the product.

Additional Information:

Our goods come with guarantees that cannot be excluded under the Australian Consumer Law. You are entitled to a replacement of the purchased product for a major failure of the product. You are also entitled to have the goods repaired or replaced if the goods fail to be of acceptable quality and the failure does not amount to a major failure. Our ventilation products also come with a two year limited warranty given by Blauberg Australasia Pty Ltd, with an office at Unit 5, 45A Eastern Creek Drive, Eastern Creek, New South Wales 2766, as set out in the instruction manual in the box. If your product does not provide the general features and functions described in the user documentation in the five year period after delivery to you, please call Blauberg Australasia Pty Ltd, ABN 85 637 003 582 on 1300 475-504 with details of your product, serial number and proof of purchase. You maybe required to return the ventilation product to the address listed, in which case such a return will be at your own cost. The benefits under this warranty are in addition to other rights and remedies that you may have at law.



FOLLOWING THE REGULATIONS STIPULATED HEREIN WILL ENSURE A LONG AND TROUBLE-FREE OPERATION OF THE UNIT



USER'S WARRANTY CLAIMS SHALL BE SUBJECT TO REVIEW ONLY UPON PRESENTATION OF THE UNIT, THE PAYMENT DOCUMENT AND THE USER'S MANUAL WITH THE PURCHASE DATE STAMP

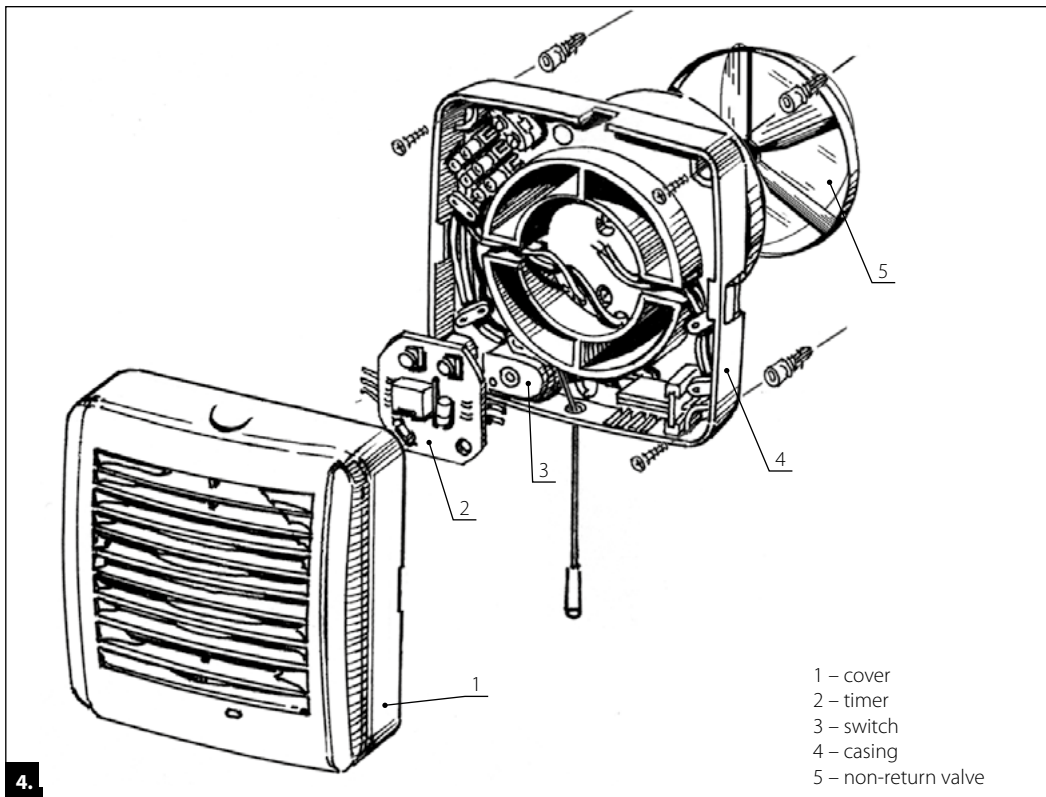

Model	Dimensions [mm]					Weight [kg]
	a	b	c	d	e	
BLABAERO 100 (T)	144	122	92	100	29	0.56
BLABAERO 125	168	144	97	125	30	0.73
BLABAERO 150 (T)	198	170	119	150	30	0.9

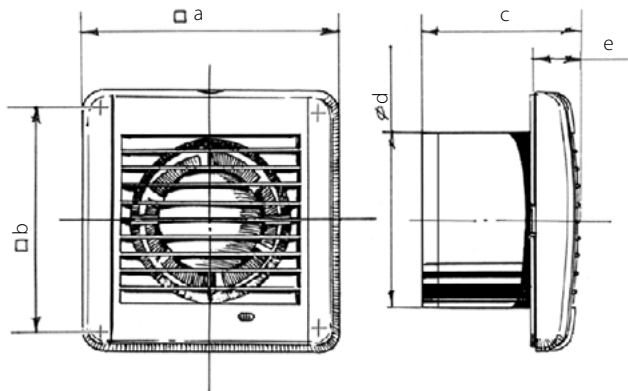

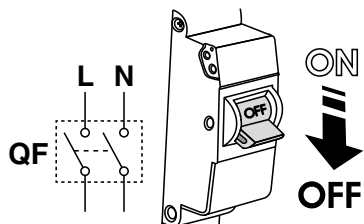

6.

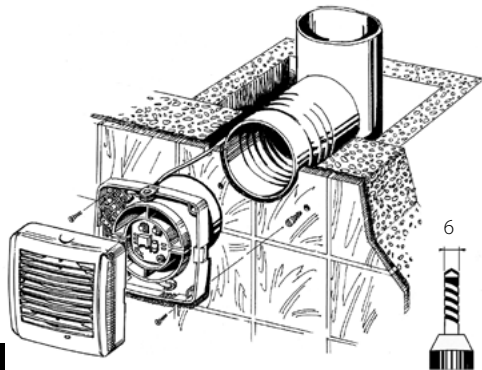

7.

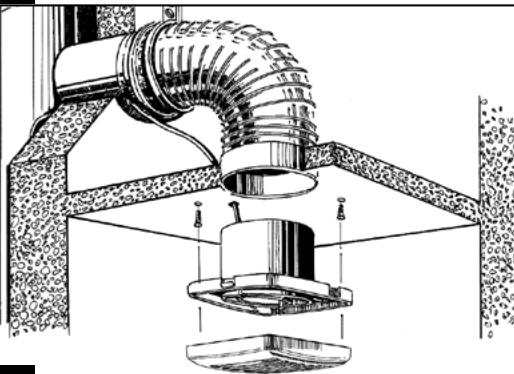

8.

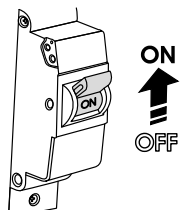

9.

BLABAERO

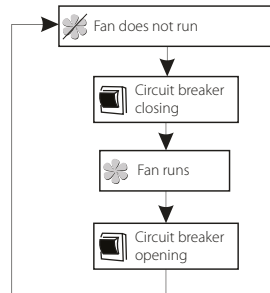
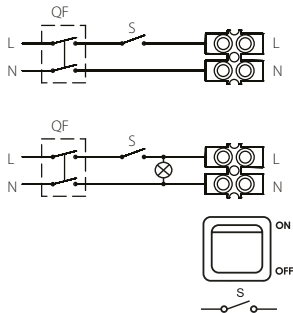

BLABAEROT

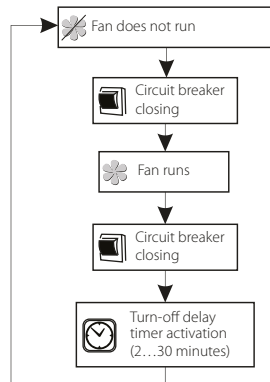
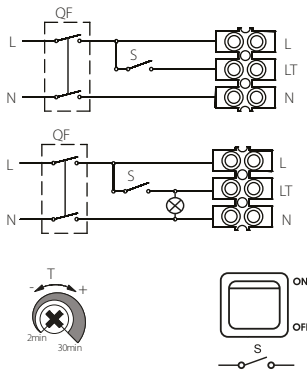

**TERMINAL DESIGNATIONS
ON WIRING DIAGRAMS**

- L – phase (220-240 V only)
- S – external switch
- N – neutral (220-240 V only)
- QF – automatic circuit breaker

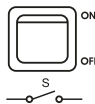

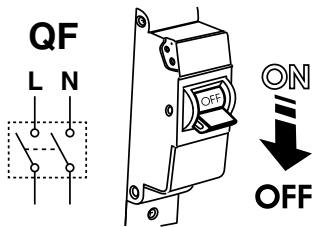

11.

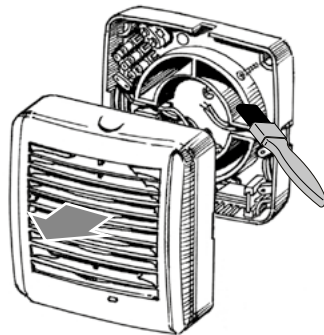

12.

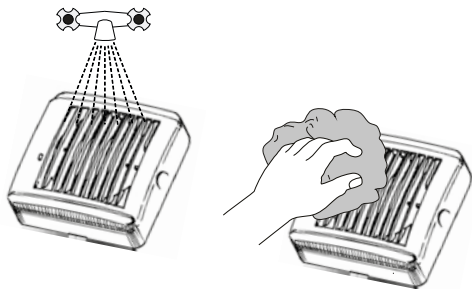

13.

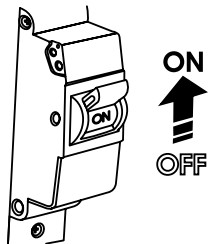

14.

Quality Inspector's Stamp

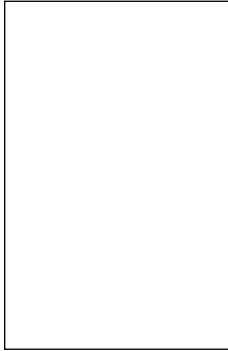

Sold by
(name and stamp of the seller)

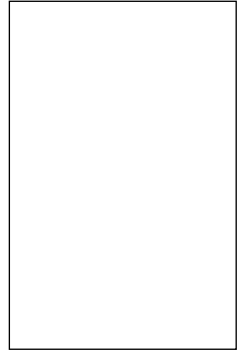

Manufacture Date

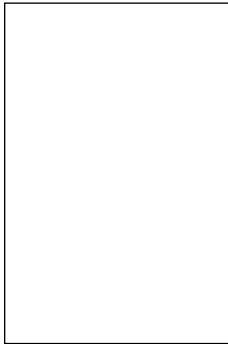

Purchase Date

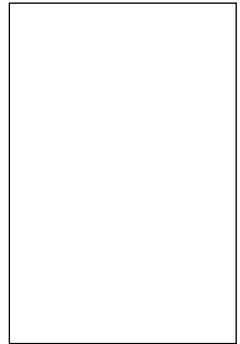

BLABAERO _____

